

Coffee System Traditional espresso coffee FAP machine, 1 group, 6.3 liter boiler, steam & water

ITEM # _____

MODEL # _____

NAME # _____

SIS # _____

AIA # _____



602577 (UMIRA1DHACL)

Traditional espresso coffee with capsule (FAP) machine, 1 group, 6.3 liter boiler, 4 programmable dosing program, Steamglide lever, manual water

Short Form Specification

Item No. _____

The MIRA line takes on the challenge of offering a dynamic outline with a sleek and streamlined design combining Stainless steel, Plexiglass and chromed components. Featuring the patented DHA group in place of the traditional brewing unit, the MIRA DHA open the way to professionals willing to work with coffee capsules FAP. The DHA system make professional brewing possible of 1 or 2 espresso from coffee Capsules FAP on any MIRA models. Its technical features enable it to warrant consistently outstanding coffee quality throughout the day, while maintaining its reputation of quality and reliability that has resulting from a long-standing experience. Among its features, independent control boxes to control the volumetric commands, manual Steamglide lever to control the steam level horizontally and precisely via a ceramic cartridge, hot water dispenser with 2 programmable time-delay keys, steam dispenser with 1 programmable time-delay key

Main Features

- Automatic cleaning cycle.
- The MIRA line offers a dynamic outline with a sleek and streamlined design combining Stainless steel, Plexiglass and chromed components.
- Featuring the patented DHA group in place of the traditional brewing unit, the MIRA DHA open the way to professionals willing to work with coffee capsules FAP. The DHA system make professional brewing possible of 1 or 2 espresso from coffee Capsules FAP.
- Its technical features enable it to warrant consistently outstanding coffee quality throughout the day: independent control boxes to control the volumetric commands, manual Steamglide lever to control the steam level horizontally and precisely via a ceramic cartridge, hot water dispenser with 2 programmable time-delay keys, steam dispenser with 1 programmable time-delay key.
- Traditional espresso coffee with capsule (FAP) machine.
- 4 programmable dosing keys.

Construction

- Stainless steel body.
- Manual Steamglide lever.
- 1 group - 6.3 liter boiler.
- Manual hot water outlet.

Optional Accessories

- Steam outlet with adjustable flow PNC 871000
- Hot water outlet with adjustable flow PNC 871001
- Cappuccinatore/foamer device with two positions for hot milk and for foam only for machines without Steamair PNC 871011
- Cappuccino system/auto foam device by air injection for traditional machines only for machines without Steamair PNC 871012
- Teflon steam wand only for machines without Steamair PNC 871013
- Side milk refrigerator 8 liter nominal capacity for up to 4 liter milk containers PNC 871014
- Side milk refrigerator 8 liter nominal capacity for up to 4 liter milk containers with digital display PNC 871015

APPROVAL: _____

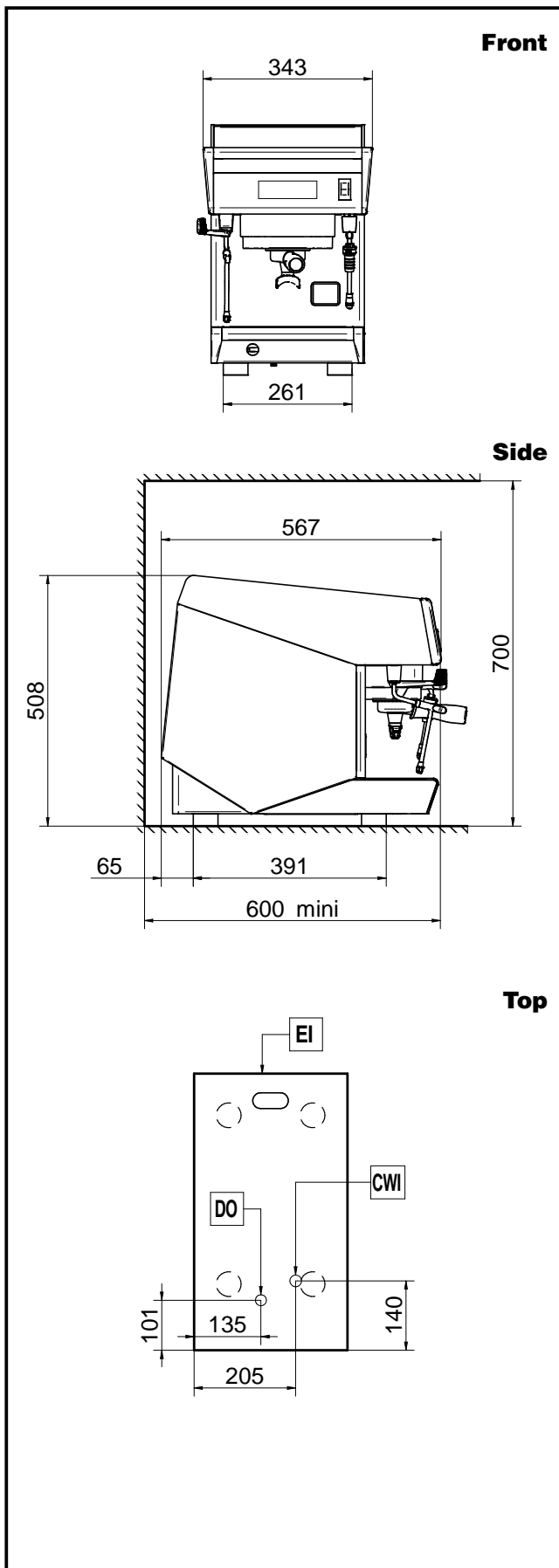

Electric

Supply voltage:

602577 (UMIRA1DHACL) 230 V/1N ph/50 Hz

Electrical power max.:

3 kW

Current consumption:

13 Amps

Plug type:

Water:

Cold water temperature (min/
max):

5 / 60 °C

Key Information:

External dimensions, Width: 343 mm

External dimensions, Depth: 570 mm

External dimensions, Height: 510 mm

Net weight: 41 kg

Shipping volume: 0.32 m³